

PROGRAMMABLE CURRENT AMPLIFIER

CA5350

Supports a Variety of Small Current Measurements,
Using Various Optical Sensors (PD, APD, PMT)

Applications

- ▶ Photodetection with PMTs and Photodiodes
- ▶ Scanning Tunneling Microscopy
- ▶ Spectroscopy
- ▶ Quantum Electronics
- ▶ Semiconductors
- ▶ MEMS
- And more...



NEW

High Gain	10^4 V/A to 10^{10} V/A (7 ranges, x10 increments), 10^{11} V/A maximum
Broad Bandwidth	DC to 500 kHz (10^6 V/A), DC to 70 kHz (10^9 V/A)
Fast Response	0.7 μs (10^6 V/A)
Low Noise	2.5 fA/ $\sqrt{\text{Hz}}$ (10^{10} V/A, at 55 Hz)
Current Suppression	± 8 nA to ± 800 μA (6 ranges)

With its unique circuitry, high gain and broad bandwidth, as well as stable operation with additional input capacitance.

The CA5350 programmable current amplifier is a variable gain type, current-input, voltage-output amplifier. Gain can be set from 10^4 V/A to a maximum of 10^{11} V/A. In addition, the included current suppression function enables the canceling of the dark current that cannot be avoided with photoelectric conversion elements such as photodiodes.

BNC connectors are used for input and output, so special cables or an external power supply are not required. The various settings, including gain, are easy to perform using the dial and keys on the front panel, and the set values are displayed on the screen.

Since the GPIB and USB interfaces make remote control also possible, gain and other settings can be performed from a personal computer, making it easy to configure an automatic measurement system.

With its performance, functions and operability, this programmable current amplifier supports the current amplification of signals from a variety of current output sensors.

High Gain and Broad Bandwidth

The CA5350 realizes unprecedented high gain and broad bandwidth support from DC to 14 kHz at 10^{10} V/A, and from DC to 70 kHz at 10^9 V/A. In addition, it also supports high-speed signals from DC to 500 kHz at 10^6 V/A or less.

Gain-frequency characteristics

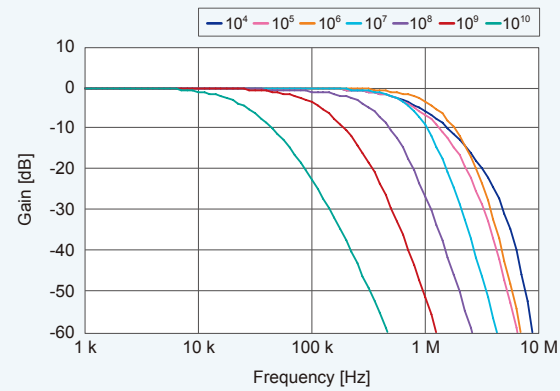

Variable Gain 10^4 to 10^{11} V/A

Gain can be set in seven ranges of 10^4 , 10^5 , 10^6 , 10^7 , 10^8 , 10^9 , 10^{10} (V/A), in x10 increments.

This enables the optimal gain setting to match the current and sensor values that vary depending on the measurement conditions.

In addition, if an output amplifier gain of x10 is used, a maximum gain setting of 10^{11} V/A is possible.

Fast Response and Stable Operation

The fast response of 0.7 μ s at 10^6 V/A gain enables support for fast pulse response signal processing in optical systems. Our unique circuit design technology enables stable operations even with the capacitance of the connecting cables and sensors, eliminating any concerns about oscillation. In addition, overshoot and ringing do not occur even for pulse responses.

By achieving both fast response and broad bandwidth, as well as stable operation even with additional capacitance on the input side, the CA5350 supports a variety of sensor types.

Pulse response characteristics
Gain: 10^9 V/A
Cs: Input-ground capacitance

Conventional current amplifiers

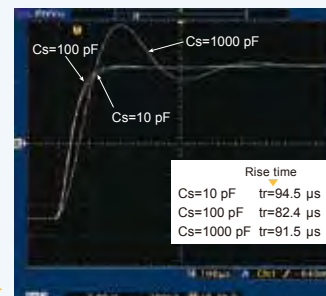

CA5350

Ringing and overshoot hardly occur.

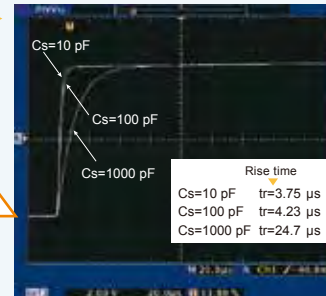

Current Suppression

For photoelectric conversion elements such as photodiodes and photo transistors, in the absence of incident light, a weak current called a dark current will flow.

In a current amplifier with high gain, a small DC current input becomes a large voltage when output, and the amplifier is saturated and measurement becomes impossible.

The built-in suppression current source is adjustable to cancel the input of such dark current.

The current suppression setting can be selected in six ranges from ± 8 nA to ± 800 μ A.

In addition, the auto-suppression function can be used to automatically set the range and current value required to suppress the dark current.

Current suppression setting screen

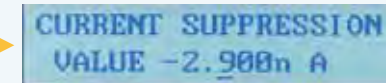

Low Noise

Built-in filters and DC power supply

The CA5350 achieves an ultra-low noise with an input-referred noise of 2.5 fA/ $\sqrt{\text{Hz}}$ (at 10^{10} V/A, 55 Hz).

In addition, in order to remove noise components and to improve the signal-to-noise ratio (SN ratio), the built-in filter can be set to a response speed in the range of 1 μ s to 300 ms to optimize the SN ratio and response speed depending on the application.

And furthermore, in our pursuit of the low noise operation that is essential to the amplification of a weak current, we have adopted a low noise DC power supply in the power supply section using our own unique technology.

Filter response speed (rise time) setting screen



Built-in System Features

Interfaces, input and output terminals

The standard-equipped USB and GPIB interfaces support remote control and integration of the CA5350 into an automatic measurement system.

Since input and output terminals are provided on both the front and rear panels, you can choose the terminals depending on how you are connecting to sensors or other equipment.

In addition, the half-rack size makes the integration of multiple units easy.

Front panel



Current input Bias output Voltage output

Rear panel

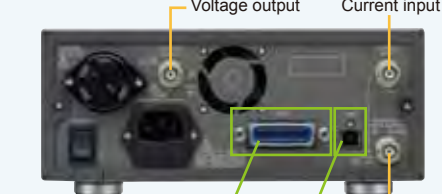

Voltage output Current input
GPIB interface USB interface Bias output

For system measurements that combine a variety of measurements.



The CA5350 programmable current amplifier can be combined with various other devices such as a lock-in amplifier, digital oscilloscope, and data acquisition system to support system measurements.

*Note: Optional single-unit and double-unit rack mount brackets are available.



Applications

- Beam position monitoring for storage rings and synchrotrons
- I-V characteristic measurement of organic thin film devices
- Gate leakage current measurement of devices such as field-effect transistors (FET) and insulated-gate bipolar transistors (IGBT)
- Detection of tunneling current of scanning tunneling microscopes (STM)
- Detection of conductive probe current for atomic force microscope (AFM) current measurement
- As a preamplifier for a lock-in amplifier

Depend on sensors and applications —

Supporting research with a variety of functions

- Bias power supply -8 V to $+8$ V
Bias power supply for applying a bias voltage to a variety of sensors
- Display backlight brightness setting
3-level setting, including OFF
Enables use in light-sensitive experiments.
- Setting memory: 10 sets

■ Input section

Input type	DC coupling unbalanced input		
Input connectors	Isolated BNC receptacle. Input switchable between front panel and rear panel.		
Non-destructive maximum input current	±30 mA		
Gain setting (V/A)	Maximum rated input current		Input impedance (Supplementary value)
	Output amplifier gain setting ×1	×10	
10 G	±1 nA	±100 pA	30 kΩ (@100 Hz)
1 G	±10 nA	±1 nA	10 kΩ (@1 kHz)
100 M	±100 nA	±10 nA	3 kΩ (@1 kHz)
10 M	±1 μA	±100 nA	1 kΩ (@1 kHz)
1 M	±10 μA	±1 μA	400 Ω (@1 kHz)
100 k	±100 μA	±10 μA	300 Ω (@1 kHz)
10 k	±1 mA	±100 μA	10 Ω (@1 kHz)

*Note 1: When input: open, input: front, filter setting: 300 μs (10 G V/A), 30 μs (1 G V/A to 10 kV/A), with no additional input capacitance.

■ Current suppression section

Range	6 ranges (8 nA, 80 nA, 800 nA, 8 μA, 80 μA, 800 μA) or OFF	
Setting range	8 nA range	-8.000 nA to +8.000 nA setting resolution 1 pA
	80 nA range	-80.00 nA to +80.00 nA setting resolution 10 pA
	800 nA range	-800.0 nA to +800.0 nA setting resolution 100 pA
	8 μA range	-8.000 μA to +8.000 μA setting resolution 1 nA
	80 μA range	-80.00 μA to +80.00 μA setting resolution 10 nA
	800 μA range	-800.0 μA to +800.0 μA setting resolution 100 nA
Setting accuracy (Supplementary value)	8 nA range	± (3.0% of setting + 0.15% of range)
	80 nA range	± (1.5% of setting + 0.15% of range)
	800 nA range	± (0.8% of setting + 0.15% of range)
	8 μA range and higher	± (0.6% of setting + 0.15% of range)

*Note: Auto suppression function is available to automatically select and set the current suppression range and current value required to cancel the input current.

■ Amplification section

Gain and accuracy (DC)			
Setting (V/A)	Output amplifier gain setting ×1	Output amplifier gain setting ×10	
10 G	1×10 ¹⁰ ±1.0%	1×10 ¹¹ ±1.0%	
1 G	1×10 ⁹ ±1.0%	1×10 ¹⁰ ±1.0%	
100 M	1×10 ⁸ ±0.5%	1×10 ⁹ ±0.5%	
10 M	1×10 ⁷ ±0.3%	1×10 ⁸ ±0.3%	
1 M	1×10 ⁶ ±0.25%	1×10 ⁷ ±0.25%	
100 k	1×10 ⁵ ±0.25%	1×10 ⁶ ±0.25%	
10 k	1×10 ⁴ ±0.25%	1×10 ⁵ ±0.25%	
Frequency characteristics (When output amplifier gain: ×1, filter: OFF, with no additional input capacitance)			
Setting (V/A)	within +0.5 dB / -3 dB	Response speed*2 (Supplementary value)	Reference frequency
10 G	DC to 14 kHz	25 μs	10 Hz
1 G	DC to 70 kHz	5 μs	
100 M	DC to 175 kHz	2 μs	
10 M	DC to 350 kHz	1 μs	
1 M	DC to 500 kHz	0.7 μs	
100 k			
10 k			
Output amplifier gain		Switchable between ×1 and ×10, gain of the converted current-voltage	
Filter	Setting range	Response speed (rise time): 1 μs to 300 ms, 1 to 3 sequences, or OFF	
	Setting accuracy	Within ±20% of set time (10% to 90% of rise time) (Supplementary value)	
	Filter characteristics	Low-pass filter (LPF), linear phase type	
	Attenuation slope	12 dB/oct	
Input/output phase		Reverse phase (When current flows into the input connector, output has negative potential.)	

*Note 2: Rise time of the square wave output waveform (10% to 90%).

Option

- Rack mount brackets (Single-unit, inch)
- Rack mount brackets (Double-unit, inch)
- Rack mount brackets (Single-unit, metric)
- Rack mount brackets (Double-unit, metric)

■ Output section

Output type	DC coupling unbalanced output
Output connectors	Provided on front and rear panels. Same signal is output to isolated BNC receptacle connectors on front and rear panels.
Maximum output voltage	±10 V (When no load)
Maximum output current	±10 mA, Total current of front and rear connectors.
Output impedance	50 Ω (Supplementary value)
Output offset voltage	within ±30 mV (Gain setting: 10 G V/A) within ±20 mV (Gain setting: 10 k to 1 G V/A) (When input: open, current suppression: OFF, output amplifier gain: ×1)

■ DC bias voltage output section

Output type	DC coupling unbalanced output
Output connectors	Provided on front and rear panels. Same signal is output to isolated BNC receptacle connectors on front and rear panels.
Setting range	-8.000 V to +8.000 V, setting resolution: 0.001 V
Setting accuracy	± (1.0% of setting + 20 mV) (When no load)
Maximum output current	±2 mA, Total current of the front and rear connectors.
Output impedance	50 Ω (Supplementary value)

*Note: DC bias voltage polarity is reversed when output.

Example: With a +1.000 V setting, the DC bias voltage output at the BNC connector is -1.000 V.

■ General

Display	Monochrome LCD, with 3-level backlight brightness setting (including OFF)
Setting memory	10 sets (1 set is fixed for use by factory default settings)
Input and output ground	Input (CURRENT INPUT), output (INVERTING OUTPUT), bias output (INVERTING BIAS OUTPUT) signal grounds are insulated from the chassis. (Signal grounds are common.) Breakdown voltage between signal ground and chassis: 42 Vpk maximum (DC + AC peak)
External control	GPIB: IEEE488.1 USB: USB 1.1 full speed, device class CDC *Note: USB driver can be downloaded from our website.
Power supply	100, 120, 220, 240 VAC ±10% (250 V or less) 50 Hz/60 Hz ±2 Hz, Power consumption: 40 VA or less Overvoltage category: II
Temperature and humidity range	Rated performance
	Operation
	Storage
Dimensions	216 (W) × 88 (H) × 400 (D) mm (excluding protrusions)
Weight	Approx. 5.0 kg (excluding accessories)
Accessories	Power cord: 1, fuse: 1, instruction manual: 1

■ Dimensions

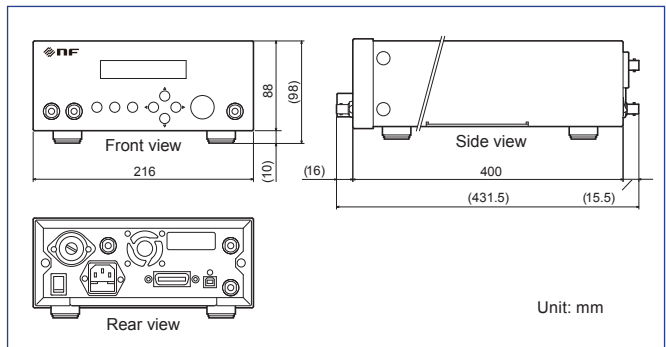

*Note: The contents of this catalog are current as of April 1, 2014.

- Product appearance and specifications are subject to change without notice.
- Before purchase, contact us to confirm the latest specifications, price and delivery date.

NF Corporation

● Head Office

6-3-20 Tsunashima Higashi, Kohoku-ku, Yokohama 223-8508, Japan
Phone: +81-45-545-8128 Fax: +81-45-545-8187

<http://www.nfcorp.co.jp/english/>